

04/2013

# Mod: TTGD-32/CB

Production code: 213221PP03F + LF039770



**Diamond**  
catering equipment

---

***INDUSTRIAL MINCER***

---

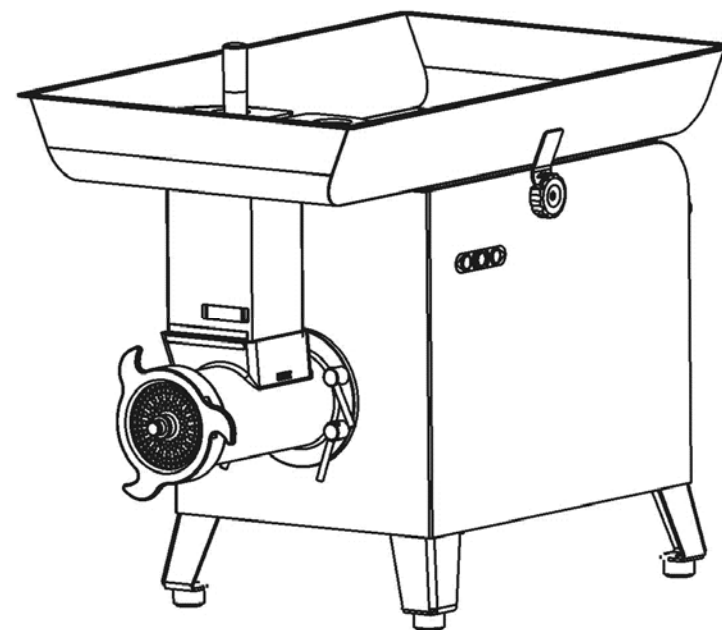

***USE AND MAINTENANCE MANUAL***

---

## Contents

<b>1. Delivery and warranty</b>	<b>5</b>
1.1 Introduction.	
1.2 Storage and use of this manual	
1.3 Warranty	
1.4 Description of the machine	
1.5 Use of the machine	
1.6 Improper uses	
1.7 Machine data	
1.7.1 Safety plates and devices	
1.8 Protections and safety devices	
1.9 Working position	
<b>2. Technical features</b>	<b>10</b>
2.1 Main elements	
2.2 Technical data	
2.3 Dimensions and weight of the machine	
2.4 Noise level	
2.5 Electrical circuit diagrams	
2.5.1 Three-phases and single-phase electrical diagram TC 32 Hp 4 - TC 42 Hp 5	
2.5.2 Three-phase and single-phase electrical diagram with overcurrent protection optional TC 32 Hp 4 - TC 42 Hp 5	
2.5.3 Three-phases and single-phase electrical diagram Hp 7	
2.5.4 Three-phase and single-phase electrical diagram with overcurrent protection Hp 7 - Hp 10	
2.6 Optionals	
2.6.1 Optional legs with wheels	
2.6.2 Optional protection against sprays	
<b>3. Controls and pilot lights</b>	<b>15</b>
3.1 List of the controls and pilot lights	
<b>4. Test, transport, delivery and installation</b>	<b>16</b>
4.1 Test	
4.2 Delivery and installation of the machine	
4.3 Installation	
4.3.1 Package disposal	
4.3.2 Handling of the machine	
4.4 Electrical connection	
4.4.1 Three-phases machine	
4.4.2 Single-phase machine	
<b>5. Start and stop</b>	<b>17</b>
5.1 Check the electrical connection	
5.2 Check the presence and efficiency of the protections and safety devices	
5.3 Check the functioning of the stop push-button	
5.4 Start up of the machine	
5.5 Machine stop	

<b>6. Use of the machine</b>	<b>18</b>
6.1 Prescriptions	
6.2 Installation of the exit opening	
6.3 Use of the mincer	
<b>7. Maintenance</b>	<b>20</b>
7.1 Lubrication	
7.2 Cleaning of the machine	
7.3 WEEE Waste of Electric and Electronic Equipment	
<b>8. Troubleshooting</b>	<b>21</b>
8.1 Inconveniences, causes and solutions.	

## **1 - Delivery and warranty**

### **1.1 - Introduction**

#### **WARNINGS!**

These symbols have been used to draw the reader's attention to dangerous points and operations and to guarantee safety to the operator and the machine.

Do not use the machine if you have not understood the warnings completely

#### **WARNINGS!**

In some drawings of this manual the machine or parts of it are shown without the protective panels or casings in order to see the components better and to make it easier to understand.

*Do not use the machine without all the necessary protections and carters correctly assembled.*

It is prohibited to partially or fully reproduce the contents of this manual.

*Any violation to copyright will lead to prosecution.*

### **1.2 - Storage and use of this manual**

This manual is meant to provide users with information and details about the transport, installation, use and maintenance of the machine. For this purpose, this manual has been provided with descriptions and drawings.

Before using the machine, carefully read this manual.

Keep this manual carefully and in an easy place to reach near the machine, to permit a quick consultation if necessary.

If the manual is damaged or lost, ask your dealer for a new copy or directly to the manufacturer.

In case the machine should be sold, inform the manufacturer with the new owner's name and address.

The current specification of this manual corresponds to the present model, however, the manufacturer has the right to update its production and the relative manuals without updating former productions and manuals, except in specific cases.

In case of any doubts, address the nearest service centre or the manufacturer itself.

The manufacturer is continuously updating its product, therefore he will welcome any suggestions or ideas that could improve the machine or the manual.

The machine has been delivered to the user under the warranty conditions valid at the purchase. For any clarifications, consult your dealer.

### 1.3 - Warranty

For no reasons the user is authorized to tamper the machine. In case of any irregularity, he must call the manufacturer.

Any user or non authorized personnel that attempts to disassemble, modify or tamper any element of the machine will lead to the invalidity of the **Conformity Statement** which complies with **EEC Directives 2006/42**, and the warranty will be voided, in this case the manufacturer is not liable for eventual damages caused to people or things due to this tampering.

Furthermore, the manufacturer is not liable in the following cases:

- an incorrect installation;
- improper use of the machine by unskilled personnel;
- use of the machine not in accordance with the regulations of the country where it has been installed;
- insufficient or wrong maintenance;
- use of non original or specific spare parts;
- not following fully or partially instructions given.

### 1.4 - Description of the machine

This mincer is a simple, compact and highly performing machine.

- As it has to be used to mince foodstuff, the parts in contact with the product have been chosen to ensure the highest degree of hygiene. The structure is made of stainless steel.
- The hopper is made of polished stainless steel to ensure the highest degree of hygiene and to facilitate the cleaning.
- The tools are made of stainless steel to ensure high resistance and hygiene.
- The machine has a modern design, it is solid and made of aluminium with the structure made of stainless steel.
- The feed openings are stainless steel casting with the possibility to apply the total or partial UNGER system.
- The machine is equipped with a reverse rotation sense of the screw propeller by means of a selector .
- The feed opening lock is rigid to give a better cut and to increase the life of the plates and knives.
- The three-phases and single-phase motors are ventilated with the following advantages:
  - maximum efficiency and life of the motor;
  - increase of the working effectiveness due to less interruptions;
  - low heating level to keep meat fresh and unchanged.

The models illustrated in this manual have been manufactured in compliance with **EEC Directives 2006/42** and following amendments. In case of accidents, the manufacturer is not liable if the machine has been modified, tampered, if the safety protections have been removed or if the machine has been used improperly.

### 1.5 - Use of the machine

The machine has been designed and manufactured to mince meat and foodstuff. The mincer must be used in professional environment and the operators in charge of the machine must belong to this specific sector and he must have read and understood this manual. The machine must be used only if it is safely installed on a work table.

The pieces of meat must enter completely in the feed opening and they must not overflow the hopper.

### 1.6 - Improper uses

The machine must be used only for the specific purpose it has been manufactured for :

- **Do not** use the machine to mince foodstuff other than meat or similar products.
- **Do not** use the machine if all the safety devices are installed and function correctly to avoid any risk to be injured.
- **Do not** reach electrical elements if the machine has not been disconnected from the power supply: **there is a risk of electric shock**.
- **Do not** operate the machine with products that cannot completely enter the hopper.
- **Do not** wear clothes that do not respect safety regulation. Consult your employer to know the safety regulations in force and the accident prevention measures to adopt.
- **Do not** turn on the machine if it is broken.
- Before using the machine, make sure that any dangerous situations have been eliminated. If you notice any irregularity, immediately stop the machine and call the person responsible of the maintenance.
- **Do not** let unauthorised personnel intervene on the machine. If there is an accident due to electrical power supply, the first thing to do, is to remove the injured person from the conductor (he has probably lost his senses).  
This operation is dangerous.  
In this case the injured person is a conductor: to touch him means to be electrocuted.  
It is necessary to disconnect the machine from the power supply immediately, if this is not possible, remove the victim using insulating materials (wood or PVC, fabric, leather, etc.). It is necessary to call the medical assistance and hospitalise the patient immediately.

### 1.7 - Machine data

The description of the machine must be precise: "**Model**", "**Serial number**" and "**Manufacturing year**", this will make things easier for our service centre. Communicate this data each time you contact this service.

Fill in the table of Fig. 1.7.1 with your machine data and use it as a memorandum:

**WARNINGS!**

Do not modify the indications of the rating plates.

Mincer model.....
Serial number.....
Manufacturing year.....
Type.....

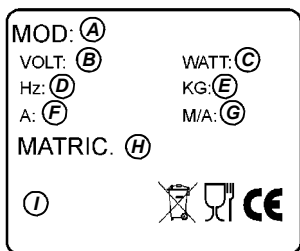

A = machine model  
 B = motor frequency volt  
 C = motor power Watt  
 D = motor frequency Hz  
 E = machine weight kg  
 F = Ampere  
 G = month and year of production  
 H = serial number  
 I = manufacturer

Fig. 1.7.1

**1.7.1 - Danger and warning plates (fig. 1.7.2)**

**WARNINGS!**

Do not perform any intervention on the electric parts when the machine is connected to the power supply.

There is a risk of electric shock.

**Comply to the warning plates. The non respect of the warning plates can cause severe injuries.**

Check that the warning plates are always installed and legible.

Otherwise install or replace them.

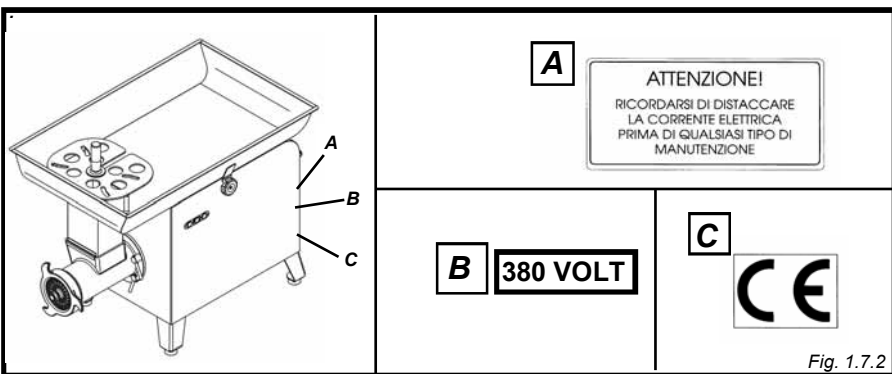

Fig. 1.7.2

**1.8 - Protections and safety devices**

**WARNINGS!**

Before using the machine, make sure all the safety devices are installed and function correctly. At the beginning of each shift check the presence and position of the safety devices. If they are not correctly installed or if they are missing, call the maintenance operator.

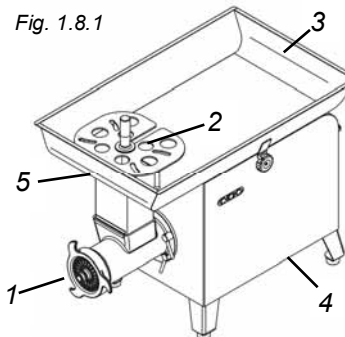

Fig. 1.8.1

1. Meat exit, plate holes of less than 8 mm. In this case the fingers cannot enter the holes. On request, it is possible to install plates with outlet holes larger than 8 mm. In this case the user must provide a protection for this opening.
2. Hand protection. The hopper is equipped with a hand protection "2" Fig.1.8. complying with the Ministry of Labour and Social Security n° 66 of the 05.09.79.

3. Stainless steel hopper solidly fixed to the feeding opening

4. Protective device for electric elements.

The lower part of the machine is closed by a protection which prohibits anything entering to the electrical elements placed inside.

5. Micro on the hopper

In the lower part of the hopper, there is a magneto at the level of the safety sensor.

**WARNINGS!**

Do never tamper the safety devices.

**1.9 - Working position**

The correct operator's position to grant an excellent work is indicated in fig. 1.9.1.

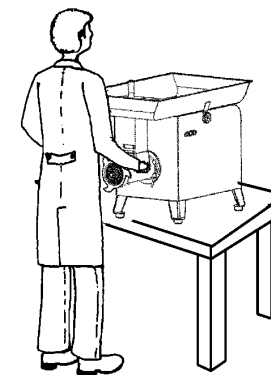

Fig. 1.9.1

## 2 - Technical features

### 2.1 - Main parts

This is a list of all the main parts of the machine illustrated in fig. 2.1.1 to make this manual easier to understand.

1. Pestle-tool
2. Controls of the machine
3. Minced meat outlet opening
4. Loading hopper
5. Feed opening

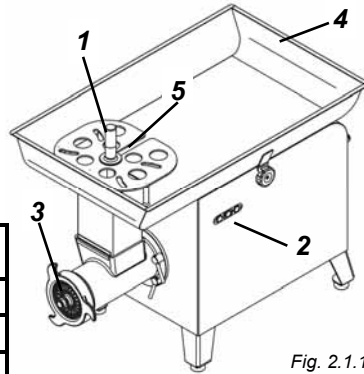

Fig. 2.1.1

### 2.2 - Technical data

	Motor	Supply	Hourly production	Plates provided
	watt/hp		kg/h.	ø mm
TC 32 HP 4	2940/4	230-400V/50Hz	700	6
TC 42 HP 5	3675/5	230-400V/50Hz	1200-1300	6
TC 42 HP 7	5145/7	230-400V/50Hz	1200-1300	6
TC 42 HP 10	7350/10	230-400V/50Hz	1200-1300	6

### 2.3 - Dimensions and weight of the machine

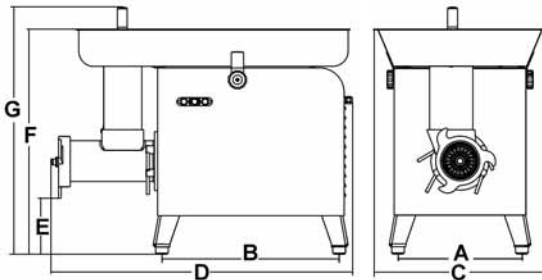

Fig. 2.3.1

	A	B	C	D	E	F	G	Net weight
TC 32 HP 4	395 mm	580 mm	560 mm	900 mm	230 mm	730 mm	800 mm	92 kg
TC 42 Hp 5	395 mm	580 mm	560 mm	970 mm	180 mm	730 mm	800 mm	91 kg
TC 42 Hp 7	395 mm	580 mm <td 560 mm	970 mm	180 mm	730 mm	800 mm	98 kg	
TC 42 Hp 10	395 mm	580 mm	560 mm	970 mm	180 mm	730 mm	800 mm	104 kg

## 24 - Noise level

The measurement of the noise level indicates that the value is lower than 70 dBA. On demand, the manufacturer can provide a copy of the noise level test.

## 2.5 - Electrical circuit diagrams

### 2.5.1 - Three-phases and single-phase electrical circuit diagram TC 32 Hp 4 - TC 42 Hp 5

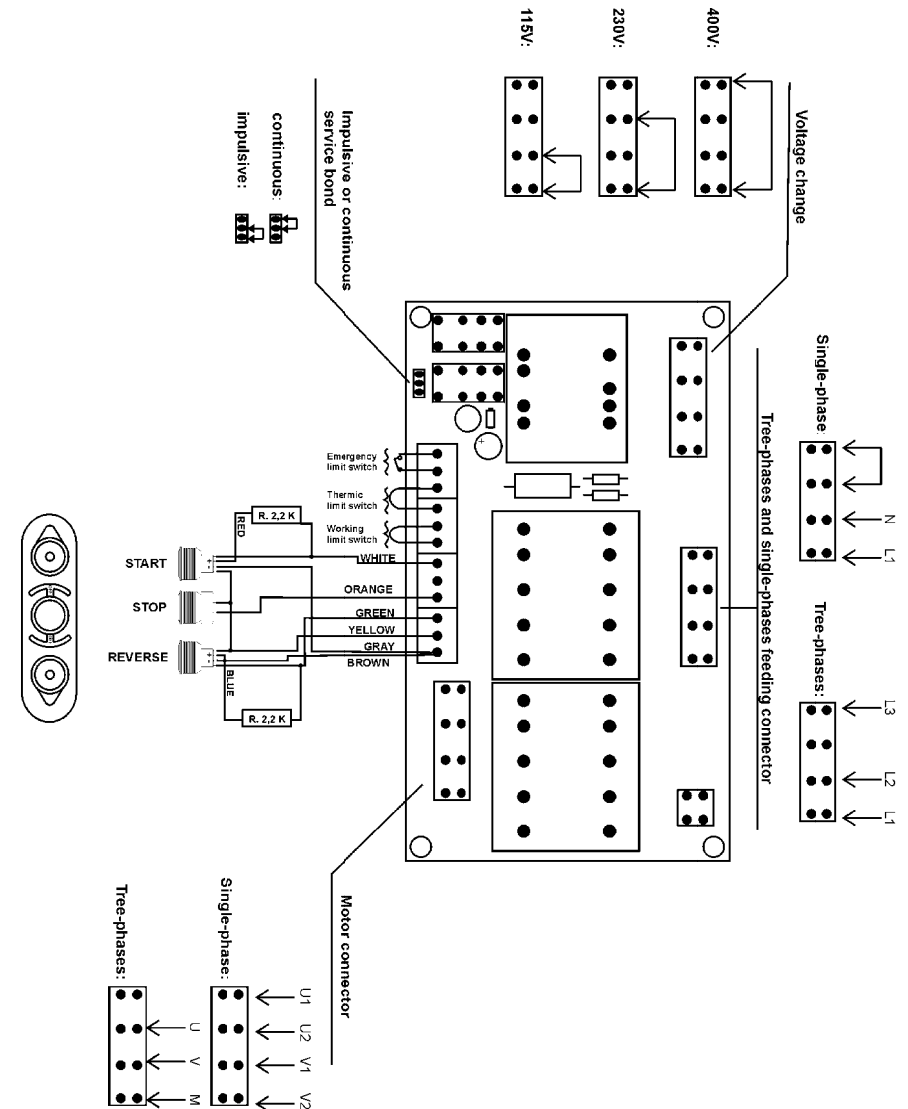

Fig. 2.5.1

2.5.2 - Three-phases and single-phase electrical diagram with overcurrent protection optional TC 32 Hp 4 - TC 42 Hp 5

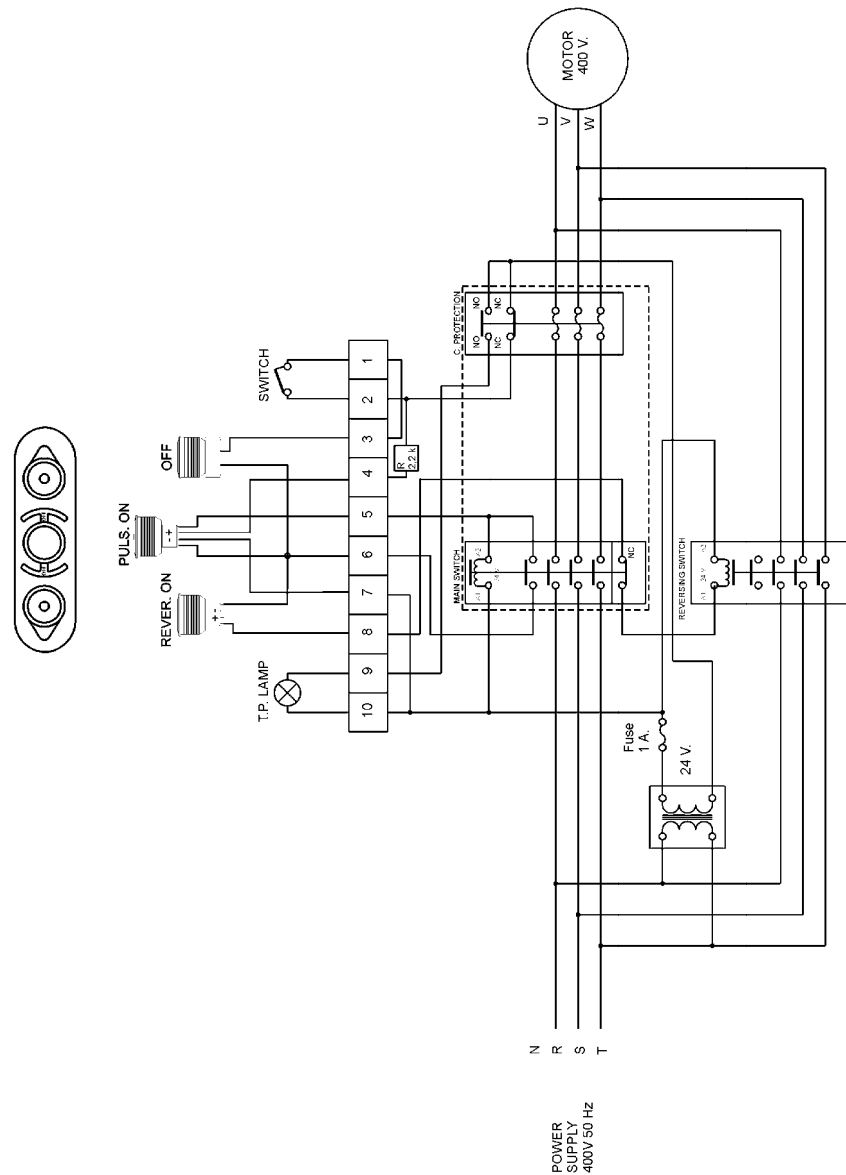

Fig. 2.5.2

2.5.3 - Three-phases and single-phase electrical diagram TC 42 Hp 7

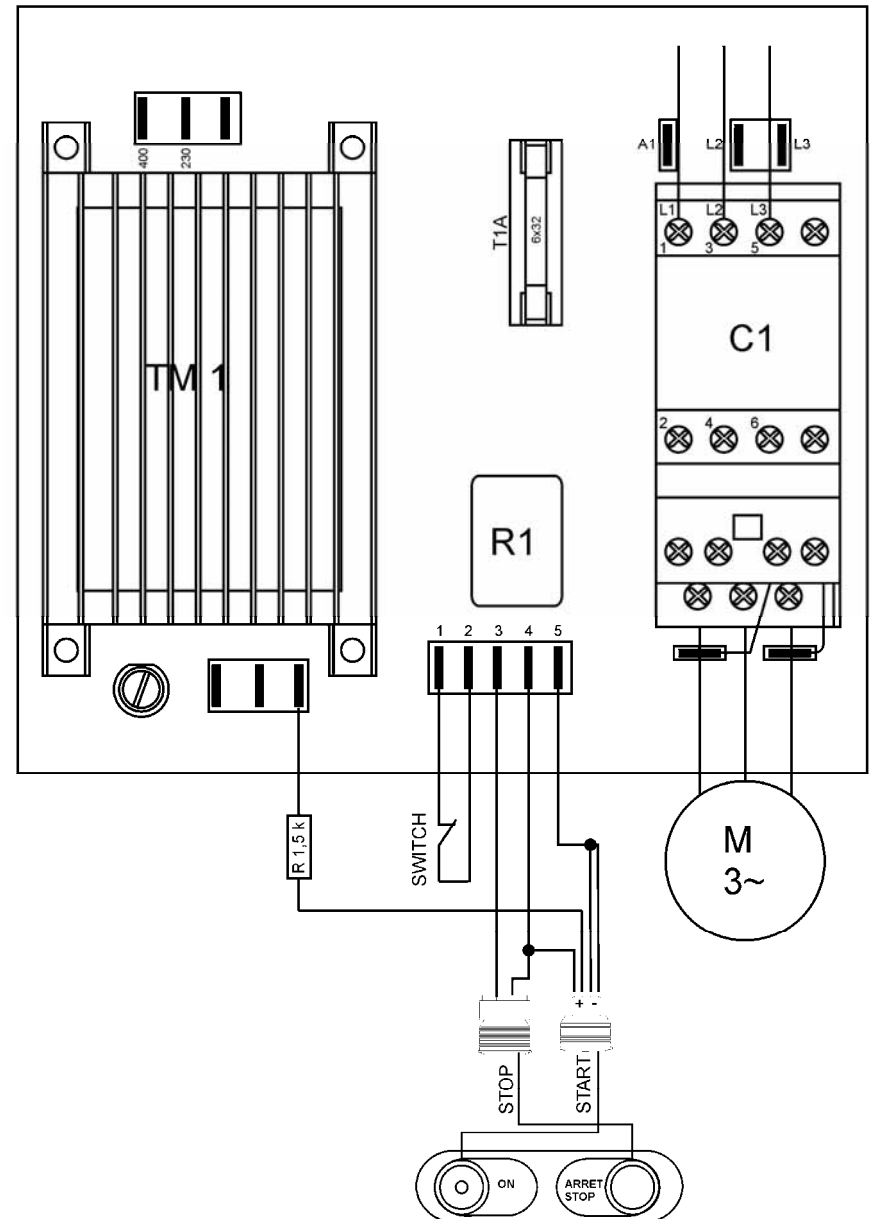

Fig. 2.5.3



### 2.5.4 - Three-phases and single-phase electrical diagram with overcurrent protection TC 42 Hp 7 - Hp 10

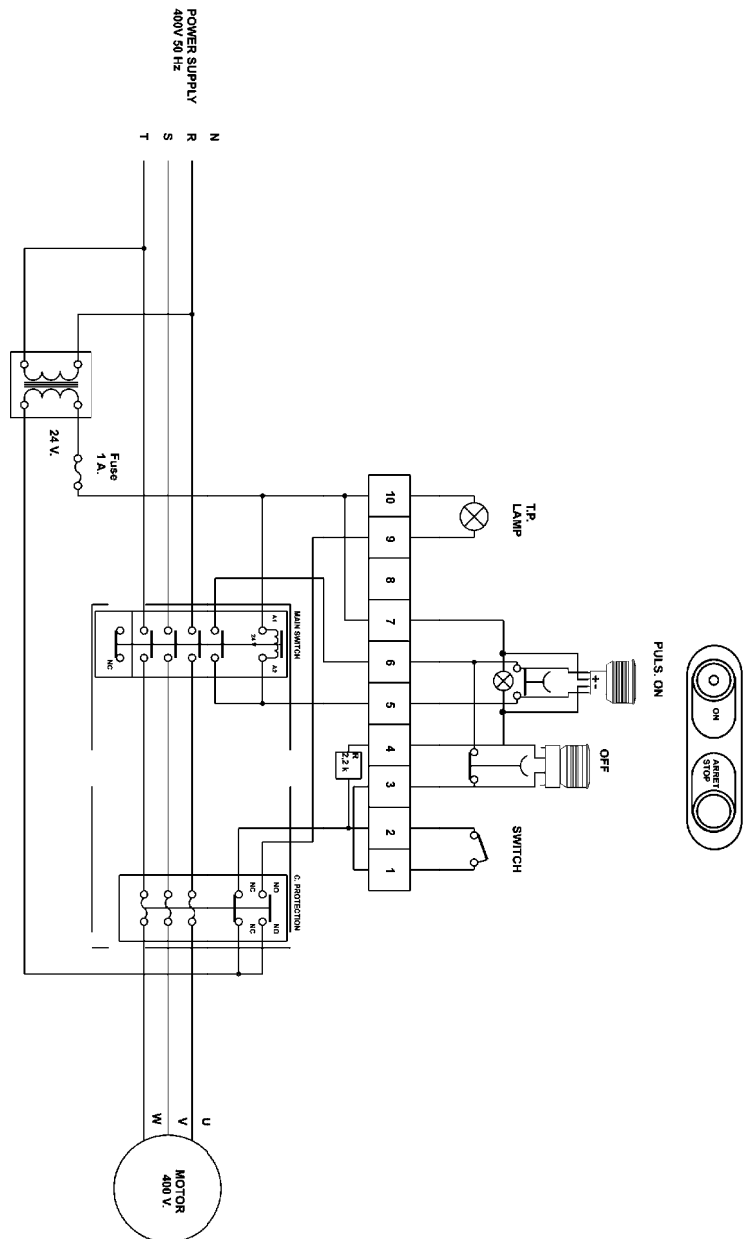

Fig. 2.5.4

### 2.6 - Optionals

#### 2.6.1 Optionals legs with wheels (A fig. 2.6.1)

Be careful when you move the machine placed on the legs with wheels. First of all, do not forget to **UNLOCK THE WHEELS** before moving it, otherwise you risk to overturn the machine and this could cause damages to the machine and it could hurt you. Moreover, check that the ground is free of holes, steps or grooves, because this could provoke the overturn of the machine.

Fig. 2.6.1

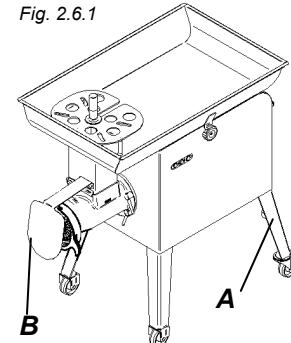

#### 2.6.2 Optional protection against sprays (B fig.2.6.1)

Protection against sprays during the mince process.

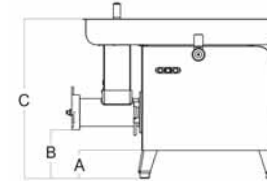

**Small legs with feet**  
 A: 126 mm  
 B: 223 mm  
 C: 730 mm

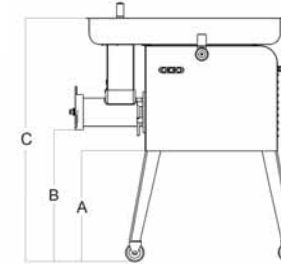

**Medium legs with wheels**  
 A: 396 mm  
 B: 493 mm  
 C: 1126 mm

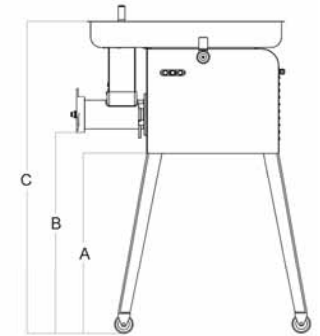

**Longer legs with wheels**  
 A: 669 mm  
 B: 866 mm  
 C: 1399 mm

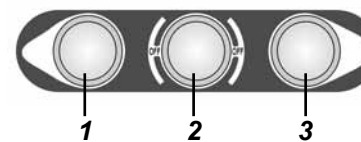
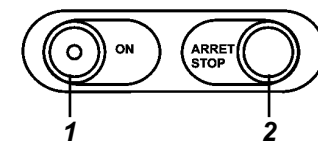

Fig. 3.1.1

**1 - Push-button "on" (continuous)**  
 - Press it to start the machine.  
**2 - Stop push-button**  
 - Press it to stop the machine.  
**3 - Reverse push-button (discontinuous)**  
 - Press it to invert the rotation sense of the propeller screw



## 4 - Testing, transport, delivery and installation

### 4.1 - Testing

Your machine has been tested on our site to ensure that it is in full standard working order.

### 4.2 - Delivery and installation of the machine

All the material delivered has been checked accurately before dispatching to the carrier.

Unless there are particular agreements with the customer, or for expensive delivery, the machine is packed in card board boxes.

When the machine arrives, check the integrity of the package.

If the package has been damaged, sign the delivery note adding: "I accept with due reservations..." and indicate the reasons.

Open the package and if the material is really damaged, inform the carrier within three days from the delivery date indicated on the shipping documents.

### 4.3 - Installation

#### WARNINGS!

The area where you intend to install the machine must be horizontal and solid and the table must be adequate to support the machine safely.

Furthermore it is necessary to leave a free area around the machine considering the supporting dimensions.

This makes things easier for the user to move while working and ensures access to the machine for maintenance purposes.

Install an adequate lighting around the machine to ensure good visibility to the operator of the mincer.

#### 4.3.1 - Package disposal

The package material such as cardboard boxes, nylon, wood can be eliminated with urban solid waste; therefore they can be eliminated easily.

Nylon is a polluting material, if burned, it produces toxic smoke. Do not burn it and do not let it in the environment but eliminate it in compliance with the regulation in force.

If the machine is delivered in countries where there are special regulations, eliminate the package in accordance with the regulation in force.

#### 4.3.2 - Handling of the machine

#### WARNINGS!

Handle the machine carefully, avoiding any accidental shock which could damage it seriously.

Machine is heavy, so it has to be moved by at least two people.

## 4.4 - Electrical connection

#### WARNINGS!

Check that the electrical power supply corresponds to the value indicated on the rating plate of the machine.

All these interventions must be performed exclusively by skilled technicians authorized by the responsible.

Connect the machine to a line equipped with an efficient ground installation.

### 4.4.1 - Three-phases machine 380 Volt-50Hz and three-phases machine 220 Volt-50 Hz

The mincer is equipped with a power supply cord with section 4 x 1,5 mm.

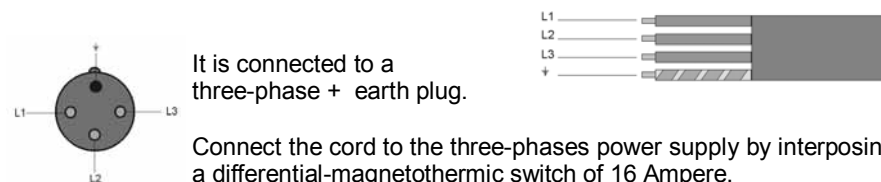

### 4.4.2 - Single-phase machine 220 Volt-50 Hz

The mincer is equipped with a power supply cord with section 3 x 1,5 mm.

It is connected to a three poles single-phase plug.

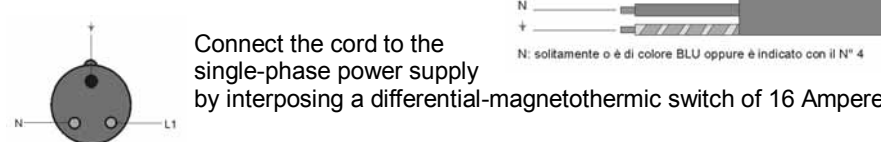

For the installations with other voltages, consult the manufacturer. If you need to lengthen the power supply cord, use a cord of the same section as the one provided by the manufacturer.

## 5 - Start and stop

### 5.1 - Check the electrical connection

Connect the plug to the power supply;

Press the on push-button ("1" Fig. 3.1.1), and check the rotation sense of the tools (for the three-phase model 380).

The rotation sense of the propeller screw must be anticlockwise.

If the rotation sense is not correct, disconnect the machine from the power supply and call the after-sale service.

#### Note:

For the machines connected to a single-phase line, the rotation sense is set by the manufacturer.

### 5.2 - Check the presence and efficiency of the protections and safety devices

#### 1 - Product exit opening.

Check that the diameter of the holes of the product exit opening is smaller than 8 mm.

If it is not, the user must install an adequate protection on the opening.

#### 2 - Hands protection

The hopper must be equipped with hand protection.

#### 3 - Stainless steel hopper.

The stainless steel hopper must be fixed correctly to the structure.

#### 4 - Protective cover for electric parts.

Check the presence, the integrity and the correct fixing of the electric parts protective cover.

### 5.3 - Check the functioning of the stop push-button (fig. 5.3.1)

Connect the machine to the power supply and make it work, then press the stop push-button "2" Fig. 5.3.1. The machine has to stop.

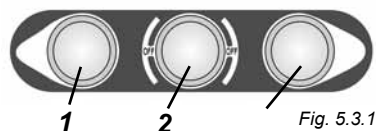
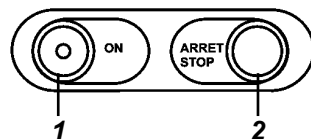

Fig. 5.3.1

### 5.4 - Start up of the machine (fig. 5.3.1)

To start the machine, connect the plug in the power supply outlet and press push-button "on" "1" Fig. 5.3.1 and the machine starts.



### 5.5 - Stopping the machine (fig. 5.3.1)

To stop the machine, press stop push-button, "2" Fig. 5.3.1 and the machine stops.

## 6 - Use of the machine

### 6.1 - Prescriptions

#### WARNINGS!

Only the authorized personnel can intervene on the machine.

Before using the machine, the operator must check that all the protections and safety devices are correctly installed and working. Otherwise stop the machine and call the person in charge of the maintenance.

The shape and volume of the product must be adequate to enter in the feeding opening, it must be pushed inside by means of the pestle **NEVER DO IT WITH YOUR HANDS.**

### 6.2 - Installation of the exit opening and pestle.

The machine can be equipped with three kind of cut:

A - Enterprise or normal

B - Half UNGER

C - Total UNGER

- System -C-, (Total UNGER ), consists of a: conveying screw propeller "1" to convey the meat, a hammer mill plate "2", the first knife "3" the correspondent drilled plate "4", the second knife "5" with the final drilled plate "6".

- System -B-, (Half UNGER), substitutes the spacer "7" to the knife "5" and plate "6".

- System -A-, (Normal), is the simplest method, as it only consists of the conveying screw propeller, a knife and an exit plate.

It is not possible to assemble the plate of unit -C- or -B- on the types with minced unit "A", it is necessary to substitute the whole unit.

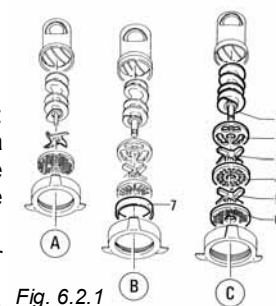

Fig. 6.2.1

### 6.3 - Use of the mincer

- 1 Check that the voltage corresponds to the value indicated on the rating plate. The voltage indicator must be on to indicate the power supply connection.
- 2 Slightly tighten the ring nut of the mincer and introduce some meat, press start push-button checking that the screw propeller rotation sense is anticlockwise.
- 3 If the meat cut goes out well, the ring nut regulation is sufficient, if it is not, tighten the ring nut until you obtain a perfect meat cut.
- 4 Stop the machine pressing the stop push-button
- 5 Accurately clean the machine and then reassemble the feeding opening and fix it, these operations are necessary to make sure that the feed opening is correctly installed.
- 6 Now you can install the screw propeller, the knife, the plate and the ring nut.

## 7 - Maintenance

### WARNINGS!

Any maintenance or cleaning operation of the mincer must be performed only if the machine is disconnected from the power supply.

The area where you perform maintenance operations must always be clean and dry.

Do not let unauthorised personnel to intervene on the machine.

Any parts, including the tool must be substituted by original spare parts.

### 7.1 - Lubrication

The machine does not require any lubrication.

### 7.2 - Cleaning of the machine

#### WARNINGS!

Before cleaning the machine, disconnect it from the power supply.

Never clean the machine with a water jet.

It is compulsory to use atoxic detergents, in respect with food hygiene regulations.

### 7.3 - WEEE Waste of Electric and Electronic Equipment

**Directive 2002/95/EC, 2002/96/EC and 2003/108/EC on the restriction of the use of certain hazardous substances in electrical and electronic equipment, and waste electrical and electronic equipment**



This symbol, crossed out wheeled bin, on the product or on its packaging indicates that this product must not be disposed of with your other household waste.

Separate waste collection of this appliance is organised and managed by the manufacturer. It is the user's responsibility to contact the manufacturer and follow the waste treatment system the manufacturer has adopted for separate waste collection.

The separate collection and recycling of your waste equipment at the time of disposal will help to conserve natural resources and ensure that it is recycled in a manner that protects human health and the environment.

## 8 - Troubleshooting

### 8.1 - Problems, causes, solutions

Problems	Causes	Solutions
- The machine does not start	- The differential switch is on position "0". - The outlet switch is on position "0" - The push-button "on" does not work. - The electrical motor is faulty.	- Turn the switch to position "I" - Turn the switch to position "I" - Call the technical service centre - Call the technical service centre
- The screw propeller does not turn in the sense indicated by the arrow (on three-phases model)	- The motor wires are inverted	- Call the technical service centre (dealer).
- The product is not minced correctly	- The plate and the knife are not tightened correctly - There is some rust on the plate and knife, they do not stick perfectly to each other (on the surface of the plate) - The feed opening is not installed correctly	- Tighten correctly the plates and knife - Replace the faulty plate and knife  - Fix correctly the feeding opening